

Connection Solutions to Meet the DCA6 Prescriptive Residential Wood Deck Construction Guide

(Based on the 2015 International Residential Code)



The Design for Code Acceptance DCA6 Prescriptive Residential Wood Deck Construction Guide — 2015 IRC version publication by American Wood Council, provides prescriptive methods for the construction of single-level decks to meet the provisions of the 2015 International Residential Code (IRC). Information is included where the IRC has yet to develop provisions. The prescriptive methods shown are not meant to limit the use of alternate means and methods that are not shown. If there are any conflicts between the DCA6 and IRC, the IRC provisions govern.

This technical bulletin provides Simpson Strong-Tie® connector, fastener, and anchor solutions to meet the DCA6 provisions. Additional alternate methods are included. Reference to other Simpson Strong-Tie documentation is made for full installation information and additional technical detail.

Simpson Strong-Tie recommends that deck designs be approved by the local building department before construction begins.

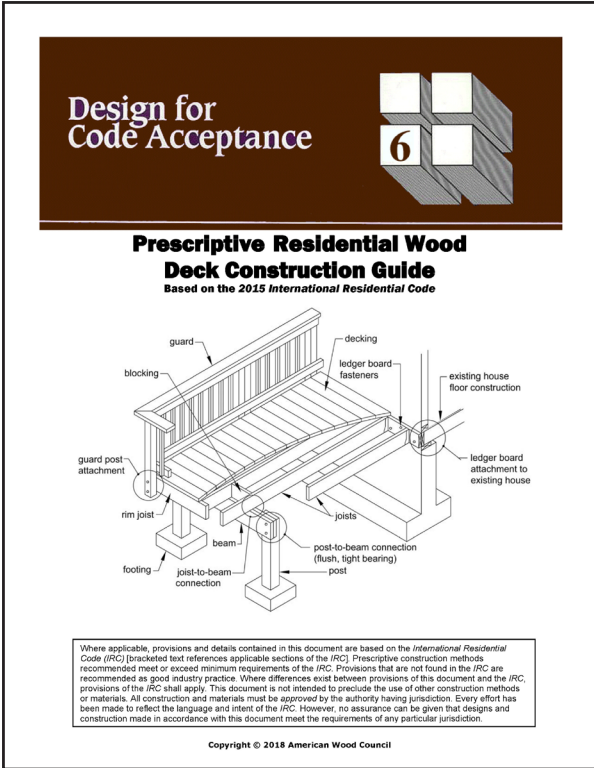

Courtesy, American Wood Council, Leesburg, VA

General notes for the use of this document:

- The DCA6 scope applies to single-level residential wood decks. Maximum live or snow loads are 40 psf. Large point loads, such as hot tubs, are outside the scope. Lateral loads are addressed to the extent of the IRC provisions.
- Connector, fastener and anchor solutions contained in this document are equivalent to DCA6 provisions, unless noted otherwise. Additional options may be available on strongtie.com.
- Framing lumber wood species: SPF, HF, DF and SP lumber.
- Solutions include wet service adjustment.
- Nails for nailed stainless steel connectors must be Strong-Drive® SCNR Ring-Shank Connector Nails. Refer to p. 11 for further information.
- Nailed connectors may be installed alternately with Strong-Drive SD Connector screws, unless noted otherwise. Refer to p. 11 for substitution information.
- A worksheet is included to assist in the count of connectors, fasteners and anchors for a project.

Table of Contents

Decking; Beam Assembly; Joist-to-Beam.....	2	Guard Post Attachment; Guard Infill.....	8
Joist Hangers; Post-to-Beam	3	Stair Connections	9
Post-to-Beam; Diagonal Bracing	4	Trimmer Joist Hangers.....	9
Rim Joist Connection Details; Post-to-Footing.....	5	Corrosion Information	10
Ledger Board Attachments.....	6	Simpson Strong-Tie Fasteners	11
Deck Lateral Loads.....	7	Worksheet	12

Connection Solutions to Meet the DCA6 Prescriptive Residential Wood Deck Construction Guide

(Based on the 2015 International Residential Code)

Decking Requirements

DCA6 (p. 3) Attach decking to each joist with 2-8d threaded nails or 2-#8 screws

Deck-Drive™ DSV WOOD Screw
 Preservative-treated decking
 Quik Guard® coating



DSV #10x2.5
 Model No.: DSVT212 (tan color shown)
 DSVR212 (red color)

Deck-Drive DWP WOOD SS Screw
 Preservative-treated or hardwood decking
 Stainless steel (Type 305 or 316)

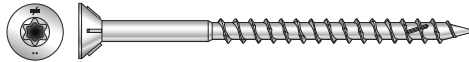

DWP #8x2.5
 Model No.: T08250WPF (type 316 SS)
 S08250WPF (type 305 SS)

Deck-Drive DCU COMPOSITE Screw
 Composite decking
 Quik Guard coating or
 Stainless steel (Type 305 or 316)



DCU #10x2.75
 Model No.: Screws have a variety of color and screw plug options to match composite color. Refer to strongtie.com/dcu for model numbers.

Note: Refer to strongtie.com for additional decking screw options and information.

Beam Assembly Details

DCA6 (Figure 4, p. 8) 10d threaded nail or #10 wood screw ≥ 3" long

DSV WOOD Screw
 Quik Guard Coating
 Model No.: DSVT3R (tan)
 DSVR3R (red)

SDWS FRAMING Screw
 Quik Guard Coating
 Model No.: SDWS16300

DWP WOOD SS Screw
 Stainless Steel
 Model No.: T10300WP (type 316 SS)
 S10300WP (type 305 SS)

Joist-to-Beam Connections (Joist Bearing on Beam)

DCA6 (Figure 6, p. 9) Options 1 and 2. 3-8d threaded toe nail or hurricane clip rated for 100 lb. of uplift and lateral load

Model No.		Fasteners (in.)	
Galvanized	Stainless	Joist	Beam
H1Z	—	(6) 0.131 x 1½	(4) 0.131 x 1½
H2.5AZ	H2.5ASS	(5) 0.131 x 1½	(5) 0.131 x 1½

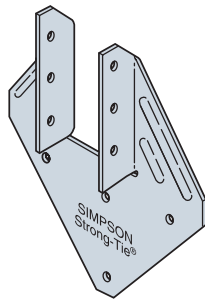

H1Z Hurricane Tie

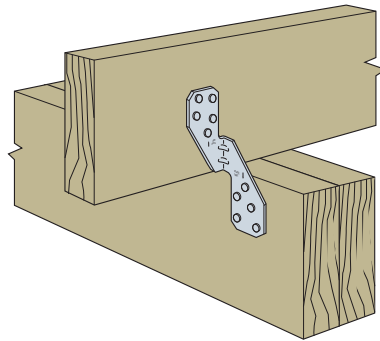

H2.5AZ/H2.5ASS Hurricane Tie
 (install with SD screws to meet full lateral load requirement)



Joist Hangers

DCA6 (Table 3A, p. 9) Hangers to meet the minimum capacity listed

Joist Size	Hanger Flange Type	Model No.		Fasteners (in.)	
		Galvanized	Stainless	Header	Joist
2x6	Standard	LUS26Z	LUS26SS	(4) 0.148 x 1½	(4) 0.148 x 3
	Concealed	LUC26Z	LUC26SS	(6) 0.148 x 1½	(4) 0.148 x 1½
2x8	Standard	LUS28Z	LUS28SS	(6) 0.148 x 1½	(4) 0.148 x 3
	Concealed	LUC26Z'	LUC26SS'	(6) 0.148 x 1½	(4) 0.148 x 1½
2x10	Standard	LUS210Z	LUS210SS	(8) 0.148 x 1½	(4) 0.148 x 3
	Concealed	LUC210Z	LUC210SS	(10) 0.148 x 1½	(6) 0.148 x 1½
2x12	Standard	LUS210Z	LUS210SS	(8) 0.148 x 1½	(4) 0.148 x 3
	Concealed	LUC210Z	LUC210SS	(10) 0.148 x 1½	(6) 0.148 x 1½

Refer to strongtie.com for additional hanger models, sizes and framing configurations.

1. Meets maximum joist span for all cases except for SPF/HF 2x8 at 24" o.c. (limit span to 8'6")

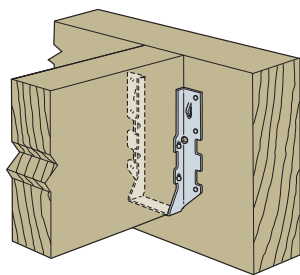

LUS Joist Hanger
(Standard flange type)

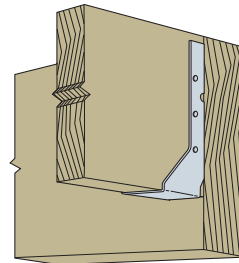
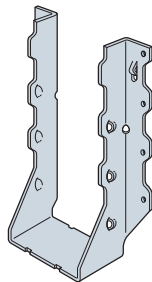

LUC Joist Hanger
(Concealed flange type)

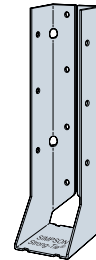

Post-to-Beam Attachment Requirements

DCA6 (Figure 8A, p. 10) (2) ½"-diameter through bolts with washers

Post Size	Fastener Model No.	Material	Condition	Screws per Post
6x6	SDWS22500DB	Double Barrier	Typical	3
			At Splice	6
	SDWS27500SS	Stainless Steel	Typical	4
			At Splice	8

SDWSxxx are Strong-Drive® structural screws. Refer to p. 11 for SDWS screw information.

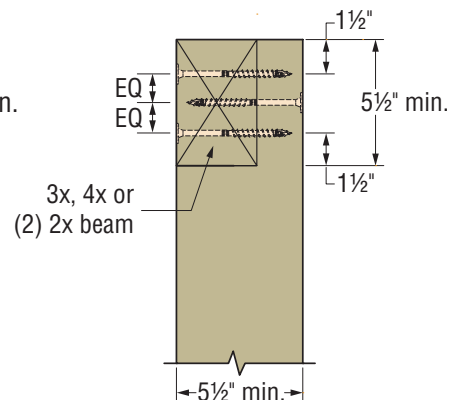
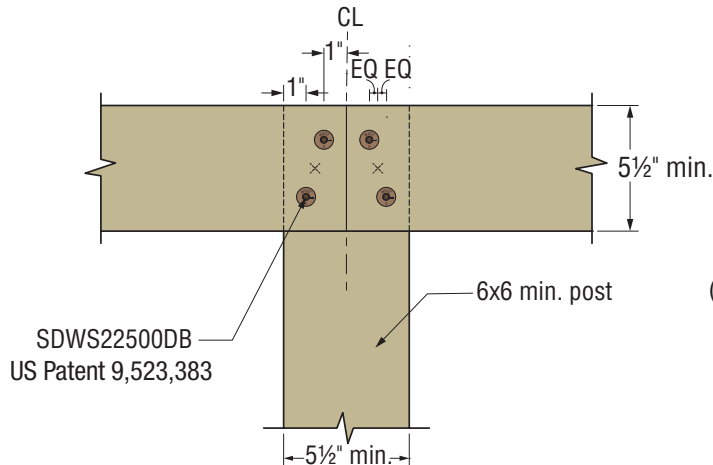

At Splice Condition with SDWS22500DB Screws
(Typical Condition is Beam Continuous Through Post)

Note: Refer to *L-F-DCA6SCREW* for installation drawings for all screws and conditions.

**Connection Solutions to Meet the DCA6
Prescriptive Residential Wood Deck Construction Guide**
(Based on the 2015 International Residential Code)

Post-to-Beam Attachment Requirements

DCA6 (Figure 8B, p. 10) Post cap attachment

Post Size	Beam Size	Model No.		Fasteners (in.)	
		Galvanized	Stainless	Beam	Post
4x4	Double 2x	LPC4Z ¹	—	(8) 0.148 x 3	(8) 0.148 x 3
		BCS2-2/4Z	BCS2-2/4SS	(8) 0.148 x 3	(6) 0.148 x 3
	4x	BC4Z	BC4SS	(6) 0.162 x 3 1/2	(6) 0.162 x 3 1/2
		PC4Z	—	(10) 0.148 x 3	(8) 0.148 x 3
6x6	Triple 2x	LPC6Z ¹	—	(8) 0.148 x 3	(8) 0.148 x 3
		BCS2-3/6Z	BCS2-3/6SS	(12) 0.162 x 3 1/2	(6) 0.162 x 3 1/2
		CCQ4.62-5.50SDSHDG	CCQ4.62-5.50SDSSS	(16) 1/4 x 2 1/2 SDS ²	(14) 1/4 x 2 1/2 SDS ²
	5 1/4" Glulam	LPC6Z ¹	—	(8) 0.148 x 3	(8) 0.148 x 3
		CCQ66SDS2.5HDG	CCQ66SDS2.5SS	(16) 1/4 x 2 1/2 SDS ²	(14) 1/4 x 2 1/2 SDS ²
	6x	PC6Z	—	(10) 0.148 x 3	(8) 0.148 x 3
		CCQ66SDS2.5HDG	CCQ66SDS2.5SS	(16) 1/4 x 2 1/2 SDS ²	(14) 1/4 x 2 1/2 SDS ²

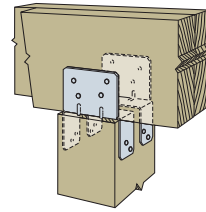

LPCZ Post Cap

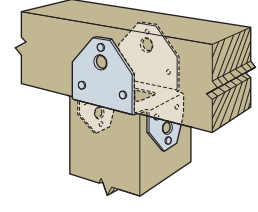

BC/BCS Post Cap

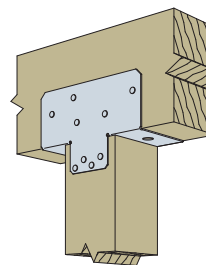

PCZ Post Cap

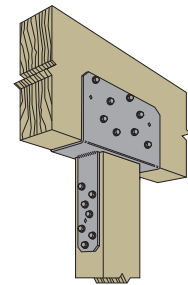

CCQ Post Cap

1. LPCZ parts installed in pairs. Fasteners are total per pair.
2. Strong-Drive® SDS Heavy-Duty Connector screws are supplied with part.

Note: Refer to strongtie.com for other post cap styles and sizes.

Diagonal Bracing

DCA6 (Figure 10, p. 10) 1/2"-diameter lag screw with washers

Model No.		Fasteners per Connector
Galvanized	Stainless	
KBS1Z	—	(12) 0.131" x 1 1/2"

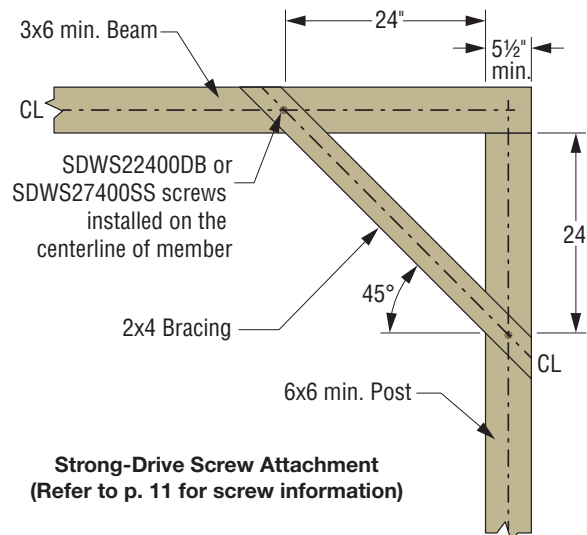
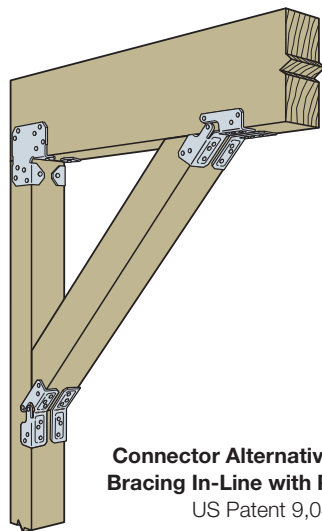

Connection Solutions to Meet the DCA6 Prescriptive Residential Wood Deck Construction Guide

(Based on the 2015 International Residential Code)



Rim Joist Connection Details

DCA6 (Figure 11, p. 11) 10d threaded nails or #10 x 3" wood screws

DSV WOOD Screw

Quik Guard® Coating
Model No.: DSVT3R (tan)
DSVR3R (red)

SDWS FRAMING Screw

Quik Guard Coating
Model No.: SDWS16300

DWP WOOD SS Screw

Stainless Steel
Model No.: T10300WP (Type 316 SS)
S10300WP (Type 305 SS)

Post-to-Footing Details

DCA6 (Figure 12, p. 13) Post bases as shown in figure

Post Size	Model No.		Fasteners (in.)	
	Galvanized	Stainless	Anchor Dia. (in.) ³	Post
4x4	ABA44Z	—	1/2	(6) 0.148 x 3
	ABW44Z	—	1/2	(8) 0.148 x 3
	ABU44Z	ABU44SS	5/8	(12) 0.162 x 3 1/2
	CPT44Z	CPT44SS	(2) 1/2	(3) 1/2 x 2 3/4 dowel ⁴
	CBSQ44-SDS2HDG ²	CBSQ44-SDS2SS ²	—	(14) 1/4 x 2 SDS ⁵
	MPB44Z	—	—	(16) 1/4 x 2 1/2 SDS ⁵
6x6	ABA66Z ²	—	5/8	(8) 0.162 x 3 1/2
	ABW66Z ²	—	1/2	(12) 0.148 x 3
	ABU66Z ²	ABU66SS ²	5/8	(12) 0.162 x 3 1/2
	CPT66Z ²	—	(2) 1/2	(3) 1/2 x 4 3/4 dowel ⁴
	CBSQ66-SDS2HDG ²	CBSQ66-SDS2SS ²	—	(14) 1/4 x 2 SDS ⁵
	MPB66Z	—	—	(24) 1/4 x 2 1/2 SDS ⁵

1. All model numbers meet maximum dimension lumber deck beam spans (DCA6 Table 3A).
2. Models noted also meet maximum glued laminated timber beam spans (DCA6 Table 3B).
3. Anchor bolt may be cast-in-place or post-installed.
4. Dowels supplied with part.
5. Strong-Drive® SDS Heavy-Duty Connector Screws are supplied with part.

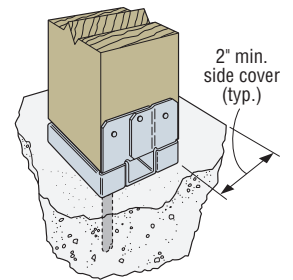

Typical ABAZ Post Base Installation

Note: Refer to strongtie.com for other post base styles and sizes.

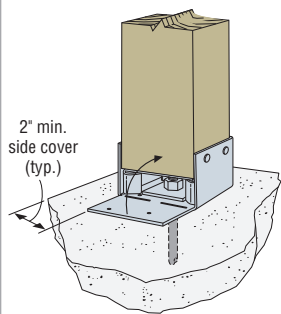

ABW Post Base

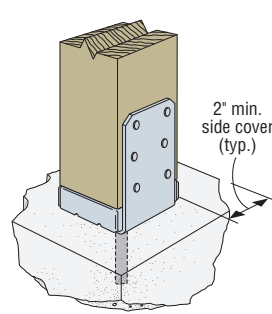

ABU Post Base

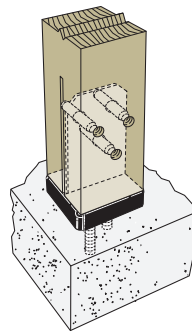

CPTZ Concealed Post Tie

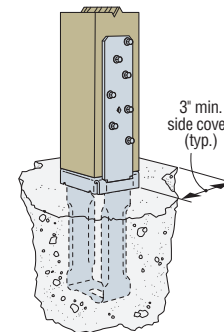

CBSQ Post Base

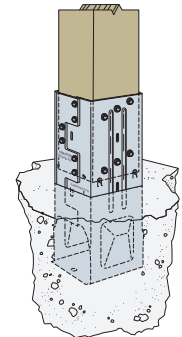

MPBZ Moment Post Base
US Patent Pending

Note: Refer to strongtie.com for MPBZ footing examples.

Post Base Anchorage with Stainless-Steel Titen HD® Heavy-Duty Screw Anchors

Post Size	Model No.		Anchor Size (Dia. x Length) (in.)	Model No.	
	Galvanized	Stainless		Type 304 SS	Type 316 SS
4x4	ABA44Z	—	1/2 x 6	THD50600H4SS	THD50600H6SS
	ABW44Z	—	1/2 x 6	THD50600H4SS	THD50600H6SS
	ABU44Z	ABU44SS	5/8 x 6	THD62600H4SS	THD62600H6SS
6x6	ABA66Z	—	5/8 x 6	THD62600H4SS	THD62600H6SS
	ABW66Z	—	1/2 x 6	THD50600H4SS	THD50600H6SS
	ABU66Z	ABU66SS	5/8 x 6	THD62600H4SS	THD62600H6SS

Note: Refer to L-PBTHDSS for information on using post bases with ZMAX® finish and stainless-steel Titen HD screw anchors. Refer to *Anchoring, Fastening, and Restoration Systems* catalog for other mechanical and adhesive post-installed anchor information.

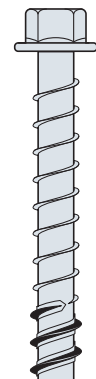

Stainless-Steel Titen HD
US Patent Pending

Connection Solutions to Meet the DCA6 Prescriptive Residential Wood Deck Construction Guide

(Based on the 2015 International Residential Code)



Ledger Board Attachment to Band or Rim Joist

DCA6 (Figure 14, p. 14 and Table 5, p. 15) 1/2"-diameter lag screws or bolts

Material or Coating	Fastener Model No. (Dia. x Length) (in.)	Rim Board Material and Min. Size	Maximum Deck Joist Span						
			Up to 6 ft.	Up to 8 ft.	Up to 10 ft.	Up to 12 ft.	Up to 14 ft.	Up to 16 ft.	Up to 18 ft.
			Maximum On-Center Spacing of Fasteners (in.)						
Double Barrier (equivalent to galvanized)	SDWS22400DB (0.22 x 4)	1" OSB/LVL	14	10	8	7	6	5	5
		1 1/8" OSB/LVL/LSL	16	12	10	8	7	6	5
		2x Solid Sawn	22	16	13	11	9	8	7
Stainless Steel	SDWS27400SS (0.276 x 4)	1" OSB/LVL	13	10	8	6	6	5	4
		1 1/8" OSB/LVL/LSL	18	14	11	9	8	7	6
		2x Solid Sawn	18	14	11	9	8	7	6

Refer to p. 11 for SDWS screw information.

1. Sawn lumber rim board shall be SP/DF/SPF/HF. Ledger shall be SP/DF/HF.
2. Fastener spacings are based on the lesser of single fastener and assembly testing, with a factor of safety of 5.0.
3. Reference *Fastening Systems Technical Supplement* for guidance on closer end distances.
4. Structural sheathing between the ledger and rim board shall be a maximum of 1/2" thick and fastened per code.

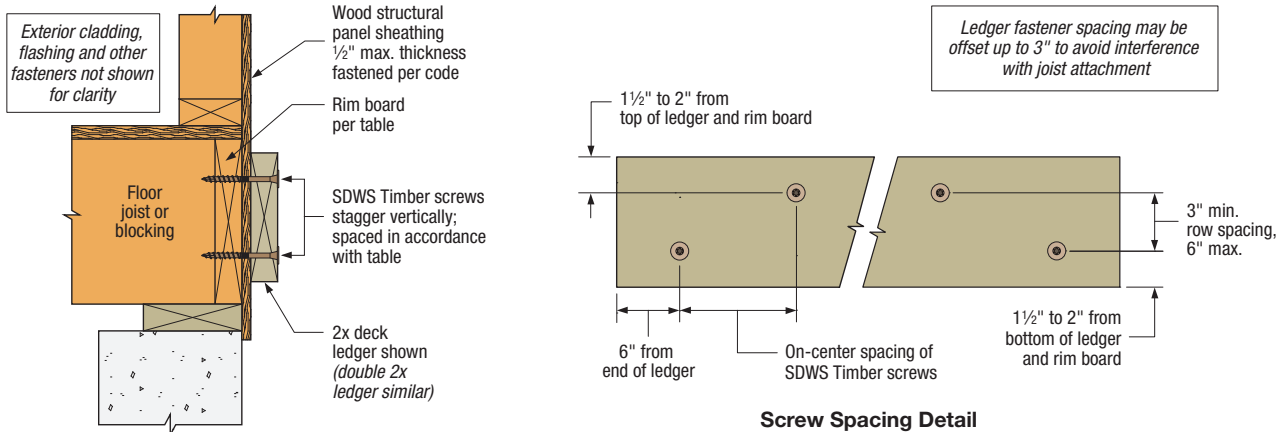

Assembly Detail

Screw Spacing Detail

Note: Refer to strongtie.com for additional information including:

- Additional screw models and options
- Information for using a 1/2" stack of washers as a spacer
- Information for double 2x ledgers
- Information for alternate loading cases
- Information for attaching ledgers to studs

Ledger Board Attachment to Foundation Wall

DCA6 (Figure 15, p. 14) 1/2"-diameter post-installed anchors

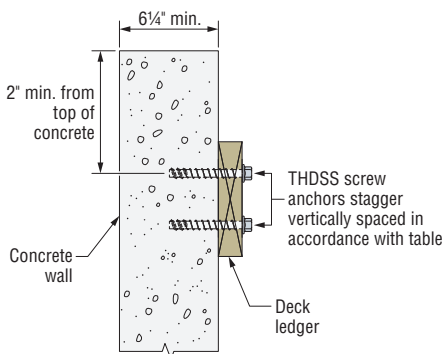

Ledger to Concrete Wall

Note: Reference L-A-THDSSLDR for spacing information.

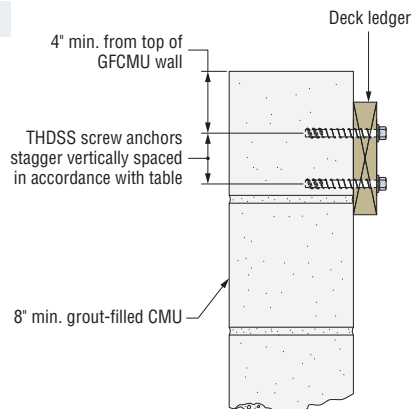

Ledger to Grout-Filled CMU Wall

Note: Reference L-A-LDGRGFCMU for spacing information.

Connection Solutions to Meet the DCA6 Prescriptive Residential Wood Deck Construction Guide

(Based on the 2015 International Residential Code)

Deck Lateral Loads (Attachment to House)

DCA6 (Figures 22–23, p. 18) 1,500 lb. holdown devices in not less than two locations within two feet of deck edge

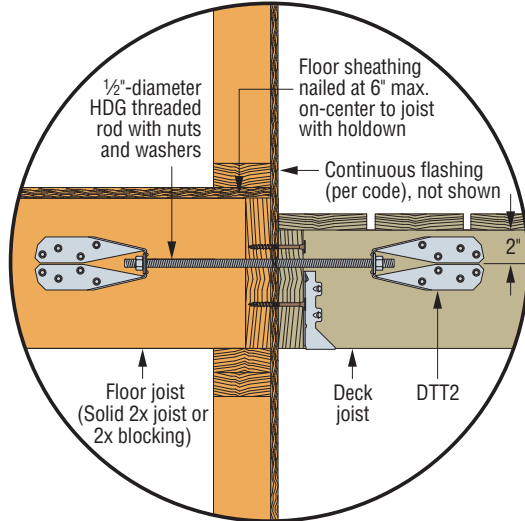

Typical DTT2 Deck-to-House Lateral Load Connection

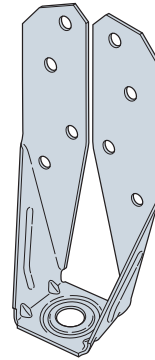

DTT2 Deck Tension Tie
US Patent 8,555,580

Alternate Option: 2015 IRC Section R507.2.4 750 lb. holdown devices at four locations evenly distributed along deck and one within 24" of each end of the ledger. Holdowns anchored to top plate, studs, or header.

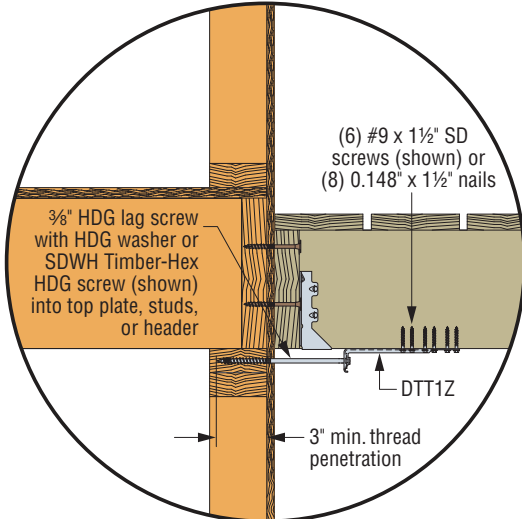

Typical DTT1Z Deck-to-House Lateral Load Connection

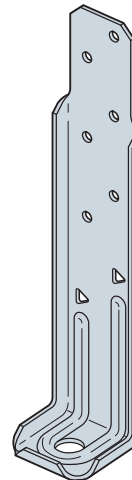

DTT1Z Deck Tension Tie
US Patent 10,865,558

Model No.		Anchor Dia. (in.)	Fasteners (in.)
Galvanized	Stainless		
DTT1Z	—	3/8 or SDWH ¹	(8) 0.148 x 1 1/2 or (6) #9 x 1 1/2 SD
DTT2Z	DTT2SS	1/2	(8) 1/4 x 1 1/2 SDS ²

- SDWH Timber-Hex HDG screw with 3" minimum thread penetration.
- Strong-Drive® SDS Heavy-Duty Connector screws are supplied with part.
- DTT1Z is also available in a kit (DTT1Z-KT) that includes (4) DTT1Z connectors, (4) SDWH screws (SDHW27800G), and (26) SD #9 x 1 1/2" screws.

Note: Refer to T-C-DECKLAT for more information on lateral load connections and conditions not shown in the DCA6 or IRC.

Connection Solutions to Meet the DCA6 Prescriptive Residential Wood Deck Construction Guide

(Based on the 2015 International Residential Code)

Guard Post Attachment

DCA6 (Figures 25–26, pp. 19–20) Holdown anchors shall have minimum allowable tension of 1,800 lb. for a 36" maximum guard height

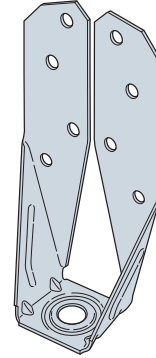
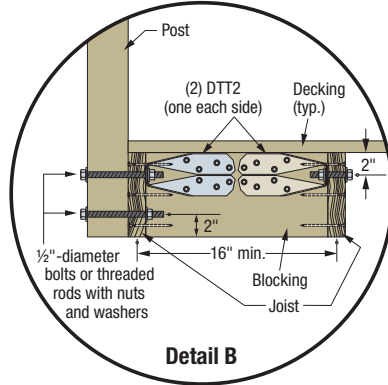
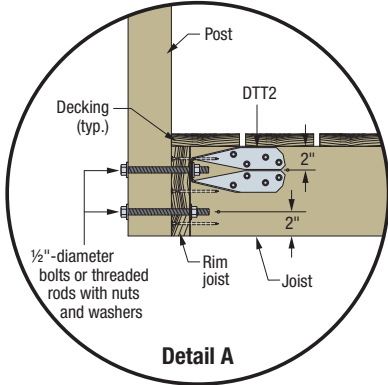

DTT2 Deck Tension Tie

Guard Post to Outside-Joist Example

(Refer to T-C-GRDRLPST for Inside-Joist Instructions)

Model No.		Anchor Dia. (in.)	Fasteners (in.)
Galvanized	Stainless		
DTT2Z	DTT2SS	1/2	(8) 1/4 x 1 1/2 SDS ¹

1. For SPF/HF lumber, use (8) 1/4" x 2 1/2" SDS (not supplied to part). Add a 2x block (species, depth and grade to match the joist) at the holdown location to provide full wood penetration for screws. Separately fasten block with (9) 0.148" x 3" nails.

Alternate Solution: SDWS Timber Screws and Blocking

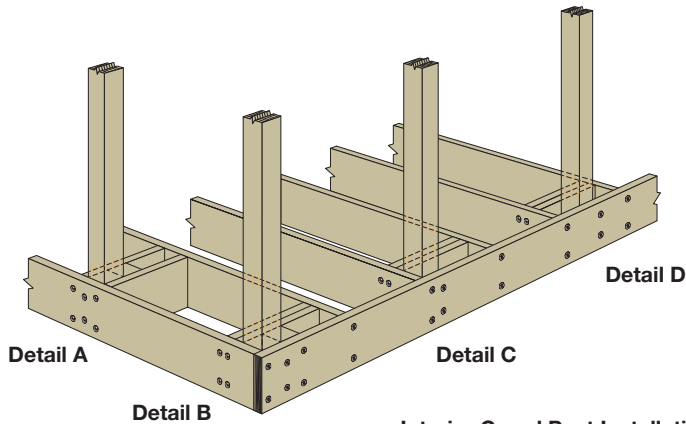

Refer to p. 11 for SDWS screw information.

Detail	Size (in.)	Model No.	Quantity Required
A	0.220 x 5	SDWS22500DB	4
	0.220 x 8	SDWS22800DB	10
B	0.220 x 8	SDWS22800DB	16
C	0.220 x 5	SDWS22500DB	8
	0.220 x 8	SDWS22800DB	6
D	0.220 x 5	SDWS22500DB	8
	0.220 x 8	SDWS22800DB	6

Interior Guard Post Installation Using Strong-Drive® SDWS Timber Screws

Note: Refer to strongtie.com for full installation details.

Guard Infill Attachment

DCA6 (Figure 24, p. 19) Rail and baluster attachment shown in example. Other methods and materials when approved.

Detail	DCA6 Specification (Figure 24)	SST Option	
		Galvanized	Stainless
Rail cap to guard post	(3) 16d threaded nails or (3) #12 x 3" screws	(4) DSV #10 x 3"	(3) SSA16D or (3) DWP #12 x 3"
Rail to post (2x4 top and bottom)	(2) 8d threaded nails or (2) #8 x 2 1/2" wood screws	(2) DSV #10 x 2 1/2" or (2) SDWS16300	(2) DWP #8 x 2 1/2"
Baluster to rail	(2) 8d post-frame nails or (1) #8 wood screw	(1) DSV #10 x 2 1/2" or (1) SDWS16212	(1) DWP #8 x 2 1/2"

For DSV/DWP product information and model numbers, refer to p. 11.

Connection Solutions to Meet the DCA6 Prescriptive Residential Wood Deck Construction Guide

(Based on the 2015 International Residential Code)

Stair Connections

DCA6 (Figures 29, 31, 34; pp. 21–22) Tread, stair stringer and stair footing connections

Tread Connections

Detail	DCA6 Specification (Figure 29)	Simpson Strong-Tie® Option	
		Galvanized	Stainless
Tread to stringer	2x or 5/4" tread: (2) 8d threaded nails or (2) #8 x 2 1/2" wood screws	(2) DSV #10 x 2 1/2"	(2) DWP #8 x 2 1/2"
	3x tread: (2) 16d threaded nails or (2) #8 x 3 1/2" wood screws	(2) DSV #10 x 3 1/2"	(2) DWP #10 x 3 1/2"
2x4 ledger to stringer	(4) 10d threaded nails or (4) #8 x 3" wood screws	(4) DSV #10 x 3" (or TA9Z/TA10Z) ^{1,2}	(4) DWP #8 x 3" (or TA9SS/TA10SS) ¹

- TA brackets are an alternative to 2x4 ledgers specified.
- May be ordered as kits with model numbers TA9ZKT and TA10ZKT. Each kit includes two ZMAX® TAs and 1/4" x 1 1/2" Strong-Drive® SDS Heavy-Duty Connector screws.

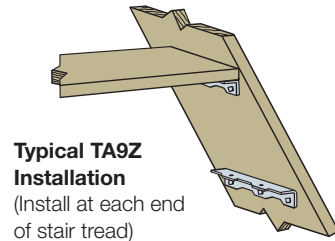

Stair Stringer Attachment

Model No.	Fastener Schedule (in.)			Maximum Supported Tributary Area		
	Rim Board	Stringer Wide Face	Stringer Narrow Face	Cut Stringer (DF/SP/HF/SPF)	Solid Stringer (DF/SP)	Solid Stringer (SPF/HF)
LSCZ LSCSS	(8) 0.148 x 1 1/2	(8) 0.148 x 1 1/2	(1) 0.148 x 1 1/2	Meets max. span and spacing	10.5 sq. ft.	9.1 sq. ft.

Note: Refer to strongtie.com for additional LSC installation conditions other than standard.

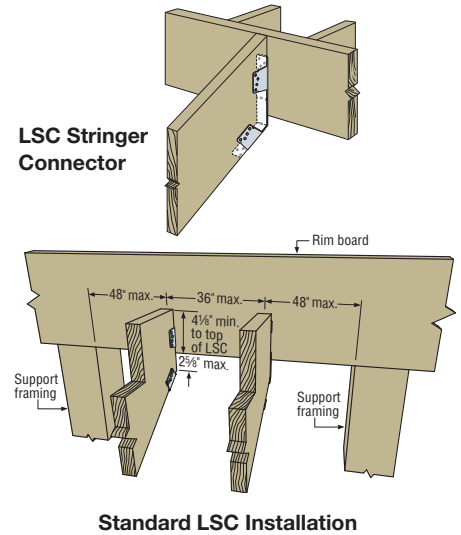

Stair Footing Connections

Detail	DCA6 Specification (Figure 34)	Simpson Strong-Tie Option	
		Galvanized	Stainless
Post to stringer	(2) 1/2"-diameter bolts	—	—
	(2) 16d threaded nails or (2) #8 x 3 1/2" wood screws	(2) DSV #10 x 3 1/2"	(2) DWP #10 x 3 1/2"
2x4 bearing block to post	(8) 16d threaded nails or (8) #8 x 3 1/2" wood screws	(8) DSV #10 x 3 1/2"	(8) DWP #10 x 3 1/2"

Trimmer Joist Hangers

DCA6 (Figure 35, p. 23) Trimmer joist hanger vertical capacity per Table 7.

Joist Size	Joist Plies	Model No.		Fasteners (in.)	
		Galvanized	Stainless	Header	Joist
2x6	2	HU26-2Z	HU26-2SS	(12) 0.162 x 3 1/2	(6) 0.148 x 3
	3	HU26-3Z	HU26-3SS	(12) 0.162 x 3 1/2	(6) 0.148 x 3
2x8	2	HU28-2Z	HU28-2SS	(14) 0.162 x 3 1/2	(6) 0.148 x 3
	3	HU26-3Z ¹	HU26-3SS ¹	(12) 0.162 x 3 1/2	(6) 0.148 x 3
2x10	2	HU210-2Z	HU210-2SS	(18) 0.162 x 3 1/2	(10) 0.148 x 3
	3	HU210-3Z	HU210-3SS	(18) 0.162 x 3 1/2	(10) 0.148 x 3
2x12	2	HU212-2Z	HU212-2SS	(22) 0.162 x 3 1/2	(10) 0.148 x 3
	3	HU212-3Z	HU212-3SS	(22) 0.162 x 3 1/2	(10) 0.148 x 3

- Hanger list for DF/SP lumber. For SPF/HF lumber, use HU210-3Z x H=7 or HU210-3SS x H=7 and install with (18) 0.162 x 3 1/2" nails into header and (10) 0.148 x 3" nails into joist.

Note: Hangers listed must be installed directly to the face of 1/2"-maximum sheathing, or the band joist/rim board. No fastener substitutions are permitted. Band joist/rim board must be thick enough for full wood penetration of header fasteners. Refer to L-C-FCMNTSHTG for additional fastening required between sheathing and band joist/rim board.

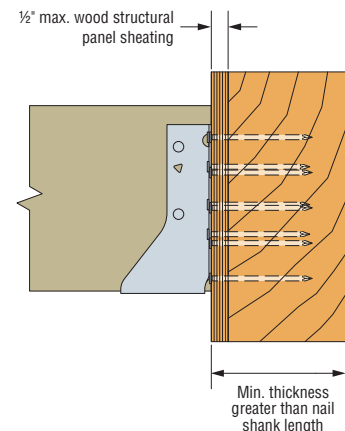

Side Elevation

Connection Solutions to Meet the DCA6 Prescriptive Residential Wood Deck Construction Guide

(Based on the 2015 International Residential Code)



Corrosion Resistance Classifications

Environment	Material to Be Fastened						
	Untreated Wood or Other Material	Preservative-Treated Wood					FRT Wood
		SBX-DOT Zinc Borate	Chemical Retention ≤ AWPA, UC4A	Chemical Retention > AWPA, UC4A	ACZA	Other or Uncertain	
Dry Service	Low	Low	Low	High	Medium	High	Medium
Wet Service	Medium	N/A	Medium	High	High	High	High
Elevated Service	High	N/A	Severe	Severe	High	Severe	N/A
Uncertain	High	High	High	Severe	High	Severe	Severe
Ocean/Water Front	Severe	N/A	Severe	Severe	Severe	Severe	N/A

Additional Considerations

- Always consider the importance of the connection as well as the cost of maintenance and replacement.
- If the information about treatment chemicals in an application is incomplete, or if there is any uncertainty as to the service environment of any application, Simpson Strong-Tie recommends the use of a Type 300 Series stainless steel. Simpson Strong-Tie has evaluated the corrosion effects of various formulations of wood treatment chemicals ACZA, ACQ, CCA, MCA, CA, and salt as corrosion accelerators. Simpson Strong-Tie has not evaluated all formulations and retentions of the named wood treatment chemicals other than to use coatings and materials in the severe category. Manufacturers may independently provide test results or other product information. Simpson Strong-Tie expresses no opinion regarding such information.
- Type 316/305/304 stainless-steel products are recommended where preservative-treated wood used in ground contact has a chemical retention level greater than those for AWPA UC4A; CA-C, 0.15 pcf (pounds per cubic foot); CA-B, 0.21 pcf; micronized CA-C, 0.14 pcf; micronized CA-B, 0.15 pcf; ACQ-Type D (or C), 0.40 pcf. When wood treated with micronized CA-C and micronized CA-B with treatment retentions up to UC4B is in dry service, hot-dip galvanized fasteners and connectors may be suitable. (PCF = Pounds per cubic foot.)
- Mechanical galvanizations C3 and N2000 should not be used in conditions that would be more corrosive than AWPA UC3A (exterior, above ground, rapid water run off).
- Some chemically treated wood may have chemical retentions greater than specification, particularly near the surface, making it potentially more corrosive than chemically treated wood with lower retentions. If this condition is suspected, use Type 316/305/304 stainless-steel, silicon bronze, or copper fasteners.
- Some woods, such as cedars, redwood, and oak, contain water-soluble tannins and are susceptible to staining when in contact with metal connectors and fasteners. According to the California Redwood Association (calredwood.org), applying a quality finish to all surfaces of the wood prior to installation can help reduce staining.
- Anchors, fasteners and connectors in contact with Fire Retardant Treated (FRT) lumber shall be hot-dip galvanized or stainless steel, unless recommended otherwise by the FRT manufacturer. Many FRT manufacturers permit low-corrosion-resistant connector and fastener coatings for dry-service conditions.
- Simpson Strong-Tie does not recommend painting stainless-steel anchors, fasteners or connectors. Imperfections or damage to the paint can facilitate collection of dirt and water that can degrade or block the passive formation of the protective chromium oxide film. When this happens, crevice corrosion can initiate and eventually become visible as a brown stain or red rust. Painting usually does not improve the corrosion resistance of stainless steel.

Coatings and Materials Available

Connectors

Level of Corrosion Resistance	Coating or Material	Description	Fastener Material or Finish
Medium		Galvanized (G185)	Hot-Dip Galvanized, Mechanically Galvanized or Double-Barrier Coating
		Hot-dip galvanized	
High/Severe	 Type 316 Stainless Steel	Type 316 stainless steel	Type 316 stainless steel

Fasteners/Anchors

Level of Corrosion Resistance	Coating or Material	Description
Medium		ASTM A153, Class D
	Double-Barrier Coating	Proprietary coating
	Mechanically Galvanized Coating	ASTM B695, Class 55
High	Quik Guard® Coating	Proprietary coating
	Type 304 and 305 SS	Type 304 and 305 stainless steel
Severe		ASTM A153, Class C
	 Type 316 Stainless Steel	Type 316 stainless steel

For more information on corrosion, environments, coatings/materials and selecting the appropriate finish for your application, visit strongtie.com/info.

Connection Solutions to Meet the DCA6 Prescriptive Residential Wood Deck Construction Guide

(Based on the 2015 International Residential Code)

Deck-Drive™ and Strong-Drive® Screws

Model Family	Model Sub Type	Length (in.)	Model No.
DSV	#10 x 2½"	2½	DSVT212, DSVR212
	#10 x 3"	3	DSVT3R, DSVR3R
	#10 x 3½"	3½	DSVT312R, DSVR312R
DWP	#8 x 2½" 316 SS	2½	T08250WPF
	#8 x 2½" 305 SS	2½	S08250WPF
	#8 x 3" 316 SS	3	T08300WPF
	#8 x 3" 305 SS	3	S08300WPF
	#10 x 3" 316 SS	3	T10300WP
	#10 x 3" 305 SS	3	S10300WP
	#10 x 3½" 316 SS	3½	T10350WP
DCU	#10 x 3½" 305 SS	3½	S10350WP
	#10 x 2¾"	2¾	Refer to strongtie.com
SDWS22	4" DB	4	SDWS22400DB
	5" DB	5	SDWS22500DB
	8" DB	8	SDWS22800DB
SDWS27	4" SS	4	SWS27400SS
	5" SS	5	SDWS27500SS
SDWS16	2½" DB	2½	SDWS16212
	3" DB	3	SDWS16300



Deck-Drive DSV WOOD Screw

Color Options: Red; Tan

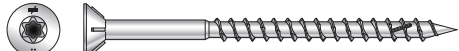

Deck-Drive DWP WOOD SS Screw

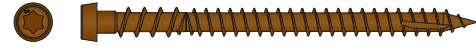

Deck-Drive DCU Composite Screw



Strong-Drive SDWS Timber Screw (SDWS22)



Strong-Drive SDWS Timber SS Screw (SDWS27)



Strong-Drive SDWS Framing Screw (SDWS16)

For use with stainless-steel connectors to achieve full connector loads.

Strong-Drive SCNR Ring-Shank Connector Nails — Stainless-Steel

Model Family	Type	Head Stamp	Size (Dia. x Length) (in.)	Model No.
SCNR	N8	8	0.131 x 1½	SSNA8
	8d Common	8	0.131 x 2½	SSA8D
	N10	10	0.148 x 1½	SSNA10D
	10d Common	10d	0.148 x 3	SSA10D
	16d Common	16d	0.162 x 3½	SSA16D

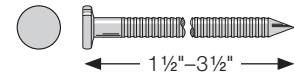

SCNR Ring-Shank Connector Nail — Type 316 Stainless Steel

Fastener alternatives for nails specified in connectors.

SD Connector Screws

Specified Nail (in.)	Replacement Fastener	
	Galvanized	Stainless Steel
0.131 x 1½	#9 x 1½" SD	#9 x 1½" SD SS
0.148 x 1½	#9 x 1½" SD	#9 x 1½" SD SS
0.148 x 3	#9 x 2½" SD	#9 x 2½" SD SS
0.162 x 3½	#10 x 2½" SD	#9 x 2½" SD SS

Note: Double shear hangers (LUS) must be installed with 2½" SD screws into joist holes.

SD Connector Screw

Mechanically-Galvanized Coating
Use with ZMAX® connectors

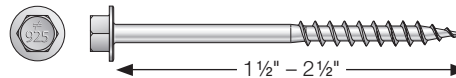

SD Connector SS Screw

Type 316 Stainless Steel
Use with stainless-steel connectors

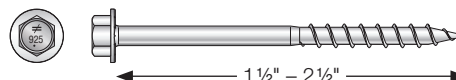

**Connection Solutions to Meet the DCA6
Prescriptive Residential Wood Deck Construction Guide**

(Based on the 2015 International Residential Code)



DCA6 Connector/Fastener/Anchor Worksheet

Job Name and Address: _____

Deck Framing

Page #	Category	Description	Item	Total
2	Decking	(2) screws x (LF decking / joist spacing, ft.)		
2	Beam Assembly	(4) screws + (beam length, ft. / 1.33)		
2	Joist-to-Beam	Clip and fasteners x number of joist crossing beams	Clip = Fasteners =	
3	Joist Hangers	Standard hanger and fasteners x number of interior joist to ledger/beam	Hanger = Fasteners =	
		Concealed hanger and fasteners x number of end joists to ledger/beam	Hanger = Fasteners =	
3, 4	Post-to Beam (Screws OR Post Cap)	Number of screws per post x number of posts	Fasteners =	
		Post cap and fasteners x number of posts	Post Cap = Fasteners =	
4	Bracing	(2) screws x number of braces	Fasteners =	
		(4) KBS1Z and fasteners x number of braces	Clip KBS1Z = Fasteners =	
5	Post-to-Footing	Post base and fasteners (and anchor, if applicable) x number of posts	Post Base = Fasteners = Anchor =	

Ledger Framing

Page #	Category	Description	Item	Total
6	Ledger Fastening	Fastener or anchor x length of ledger, in./on-center spacing, in.	Fastener/Anchor =	
7	Deck Lateral Load	EITHER: (4) DTT2 brackets and fasteners, OR (1) DTT1Z-KT, per deck level	Tie = Fasteners =	

Guard Framing

Page #	Category	Description	Item	Total
8	Guard Post (Tie OR Screws)	DTT2 x number of guard posts	Tie = Fasteners =	
		SDWS22DB screws x number of Detail A/B/C/D posts	Fasteners = Fasteners =	
8	Infill: Rail Cap	(3) fasteners per post	Fasteners =	
	Infill: Rail to Post	(2) fasteners per rail per post	Fasteners =	
	Infill: Baluster	(2) screws per baluster	Fasteners =	

Stair Framing

Page #	Category	Description	Item	Total
9	Tread to Stringer	(2) screws per tread to stringer	Fasteners =	
9	Ledger to Stringer (Ledger OR Bracket)	(4) screws per ledger per tread end	Bracket =	
		(1) tread angle bracket and fasteners per tread end	Fasteners =	
9	Stringer Attachment	(1) stringer connector and fasteners per stringer connection	Connector = Fasteners =	
9	Post to Stringer	(2) 1/2"-diameter bolts per post	Fasteners = 1/2" bolt	
9	Bearing Block	(8) screws per block	Fasteners =	

Trimmer Framing

Page #	Category	Description	Item	Total
9	Trimmer Joist Hangers	Hanger and fasteners x number of trimmer joists	Hanger = Fasteners =	

This technical bulletin is effective until June 30, 2023, and reflects information available as of July 1, 2021. This information is updated periodically and should not be relied upon after June 30, 2023. Contact Simpson Strong-Tie for current information and limited warranty or see strongtie.com.